

# **S-11018.M**

COVERED ARC WELDING ELECTRODE  
FOR 800MPa CLASS HIGH TENSILE STEEL

2020.12

---

**HYUNDAI WELDING CO., LTD.**



## ❖ Specification

AWS A5.5                      E11018-M

ISO 18275-A                  E62 2 Mn2NiMo B 1 2

## ❖ Applications

S-11018.M electrodes are recommended for applications requiring stress relieved weldments that meet AWS E11018M high strength tensile and relatively low (2.8 kgf-m at -51 °C) Charpy V-notch impact requirements. In fact impact tests are not required to meet AWS quality conformance inspection unless they are specifically requested by the customer.

S-11018.M electrodes can be used to join armor plate and high strength steel such as Hy-80, Hy-90, and Hy-100 where high X-ray quality welds are required.

## ❖ Characteristics on Usage

S-11018.M is heavy coated low alloy, low hydrogen iron power type electrode displaying fast, efficient metal transfer. The deposited metal has good x-ray performance and excellent tensile and impact properties. Deposition rates obtained are higher than with E11016.G electrode types. Extremely good crack resistibility is obtained owing to very low hydrogen content of the weld metal.

## ❖ Note on Usage

1. Dry the electrodes at 350~400°C (662~752°F) for about one hour before use and store the electrodes at 100~150°C (212~302°F) after drying them with attention to keep away from moisture.
2. Adopt back step method or strike the arc on a small steel plate prepared for this particular purpose, because arc striking on base metal is in danger of initiation cracking.
3. Keep the arc as short as possible and avoid large with weaving.
4. Preheat at 200~300°C (392~572°F).  
The temperature to be applied varies in accordance with plate thickness and kind of steel to be welded.



**Mechanical Properties & Chemical Compositions of all-Weld Metal**

❖ **Welding Conditions**

Method by AWS Rules

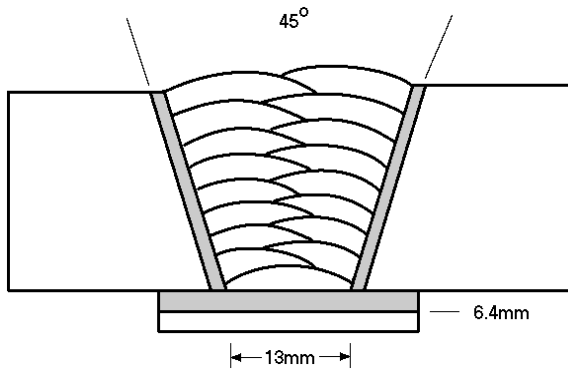

- Diameter : 4.0 X 400mm(5/32 X 16in)
- Amp./ Volt. : 170 / 23~24
- Interpass Temp. : 130 ~ 150℃(266~302°F)
- Interpass Temp. : 93 ~ 121℃(199~250°F)
- Polarity : AC or DC +

[ Joint Preparation & Layer Details ]

❖ **Mechanical Properties of The Weld Metal**

consumable	Tensile test			CVN Impact Test J (ft·lbs)
	YS MPa (lbs/in <sup>2</sup> )	TS MPa (lbs/in <sup>2</sup> )	EL (%)	-50℃(-58°F)
S-11018.M	740(107,300)	810(117,500)	21.6	50(37)
AWS Spec.	690 ~ 770 (100,000 ~ 112,000)	≥770 (≥112,000)	≥20	≥ 27(20)

❖ **Chemical Analysis of The Weld Metal(wt%)**

Consumable	Chemical Composition (%)							
	C	Si	Mn	P	S	Ni	Cr	Mo
S-11018.M	0.07	0.48	1.62	0.023	0.012	2.04	0.02	0.35
AWS Spec.	≤0.10	0.60	1.30 ~ 1.80	≤0.030	≤0.030	1.25 ~ 2.50	≤ 0.40	0.25 ~ 0.50

This information is provided solely for the purpose of confirming product conformance with applicable standards. The serviceability of a product or structure utilizing this type of information is and must be the sole responsibility of the builder/user. Many variables beyond the control of HYUNDAI WELDING CO., LTD. affect the results obtained in applying this type of information. These variables include, but are not limited to, welding procedure, shielding gas, plate chemistry and temperature, weldment design, fabrication methods and service requirements.



## Weldability & Welding Efficiency

### ❖ Weldability

Item	Division	Flat position	Vertical position
Arc stability		Good	Excellent
Melting rate		Excellent	Excellent
Deposition rate		Excellent	Excellent
Resistance of spatter occurrence		Excellent	Good
Bead appearance		Excellent	Excellent
Slag detachability		Good	Good

### ❖ Test Conditions of Deposition Efficiency

Consumable	Base Metal		Welding conditions		
	Specification	Dimension, mm(in)	Amp. (A)	Welding speed (mm/min)	Position
S-11018.M (4.0 x 400 mm) (5/32 x 16 in)	ASTM A36	300 X 100 X12 (12 X 3.9 X 0.5)	170	200	Flat

### ❖ Results of Deposition Efficiency Test

Consumable	Deposition efficiency(%)	
	For electrode	For core wire
S-11018.M 4.0mm(5/32in)	65 ~ 70	120 ~ 125

This information is provided solely for the purpose of confirming product conformance with applicable standards. The serviceability of a product or structure utilizing this type of information is and must be the sole responsibility of the builder/user. Many variables beyond the control of HYUNDAI WELDING CO., LTD. affect the results obtained in applying this type of information. These variables include, but are not limited to, welding procedure, shielding gas, plate chemistry and temperature, weldment design, fabrication methods and service requirements.



## Diffusible Hydrogen Content

### ❖ Diffusible Hydrogen Content

Diameter	: 4.0 x 400mm(5/32 x 16in)
Exposed environment	: 25 °C(77°F) and 80% Relative humidity (RH)
Exposed time	: 3~9 hours
Re-drying conditions	: 350°C X 1hr (662°F X 1hr)
Welding current	: 4.0mm = 170Amp, DC+
Test method	AWS A4.3 (Gas chromatography method)

Diffusible hydrogen content (ml/100g)				
X1	X2	X3	X4	Ave.
6.72	7.34	7.59	7.70	7.34

**Average Hydrogen Content 7.34 ml/100g Weld Metal**

### ❖ Sizes Available and Recommended Current

Diameter, mm(in)		2.6 (3/32)	3.2 (1/8)	4.0 (5/32)	5.0 (3/16)
Length, mm(in)		350(14)	350(14)	400(16)	400(16)
Recommended current range ( DC+ Amp.)	Flat (1G-PA)	55 ~90	90 ~130	130 ~190	190 ~240
	3G (PF) & 4G,5G (PE)	50 ~80	80 ~120	120 ~170	150 ~200

This information is provided solely for the purpose of confirming product conformance with applicable standards. The serviceability of a product or structure utilizing this type of information is and must be the sole responsibility of the builder/user. Many variables beyond the control of HYUNDAI WELDING CO., LTD. affect the results obtained in applying this type of information. These variables include, but are not limited to, welding procedure, shielding gas, plate chemistry and temperature, weldment design, fabrication methods and service requirements.